

## SHOPSMART: A Location-based Mobile Advertisement Publishing System

Prof. Shilpa Mene, Kalyani Shewale, Vishakha Bhadane, Prajakta Jeyure, Sayali Kakulte

Department of Information Technology,  
Savitribai Phule Pune University  
Ganeshkhind, Pune

### ABSTRACT:

Traditionally, Advertisements and coupons are commonly used today to attract the consumers by providing many discounts. Now-a-days, Consumers are using their mobile devices to actively engage with the location in various ways which opens a great opportunity for vendor to publish advertisement. The motivation for every location based information system is: "To assist with the exact information, at right place in real time with personalized setup and location sensitiveness". To have high-personalized advertising, vendors benefit from mobile locating technologies to locate customers and personalize advertisements based on the location. For vendors, ShopSmart provides a low cost and effective way to implement digital advertisement publishing mechanisms. The system is able to provide vendors not only ability to edit Advertisements but also publish it to consumers. Advertisement and coupon data desired by consumers can be viewed and he can generate its QR (Quick Response) code to be shown to respective Vendor to get discount when QR code presented is to be scanned. So, the work proposes web and mobile application for location based mobile advertisement publishing framework for Vendors and Customers location based services.

**KEYWORDS:** Mobile Advertisement, Location-Based Advertising, QR Code.

### 1. INTRODUCTION

Traditionally, Advertisements are commonly used today to attract the consumers by providing discounts. Some shops have issued various vouchers, coupons or ads to customers for the purpose of improving advertising values by providing discounts, offers on products. In order to allow consumers to retrieve more information such as location of vendors, an advertisement publishing system should be improved to meet the consumer requirements. So, Shopsmart is an information service, accessible with mobile devices through the mobile network and utilizing the ability to make use of geographical position of the mobile device.

QR code mapping for the advertisement: This is one of the main component of our project because for every advertisement we are going to provide one QR code that will contain its offers, its detail information. The term QR is derived from Quick Response, as the creator intended the code to allow its contents to be decoded at high speed. A QR code uses four standardized encoding modes (numeric, alphanumeric, byte / binary, and kanji) to efficiently store data; extensions may also be used. Applications include product tracking, item identification, time tracking, document management, general marketing, and much more.

However, consumers would like to retrieve more information such as location of vendors, how to locate them, offer details, offer validity. When Customer got URL of any advertisement, he or she may show unwillingness to type URL and get the detail information about advertisement and also to download the coupon. Always customer prefers to see the details without putting much effort to get information. Such situation decreases the customer willingness to access information.

So, to deal with these problems, our mobile application enables all the users to locate their positions and search nearby shops for the selected category and vendor editor will provide the interface for vendors to create their own profile, business details, product details and offers on the products and advertisement. On

map, consumers will find the shops under half km of particular category they chosen to go through and get more detail about the advertisement. If he or she finds advertisement useful they can generate its QR code to be saved in mobile and customer can show Vendor the encoded information through scanning the saved QR code in their mobile phone to get the stated discount.

The rest of this paper is organized in the following manner. System architecture and implementation are presented in Section 2. Prototype is described in Section 3. Finally, conclusions and future work are described in Section 4 and 5.

## 2. SYSTEM FRAMEWORK AND IMPLEMENTATION

In this section the proposed system architecture is described, including system architecture, consumer component, vendor component, advertisement editor, editing process, uploading process, capturing process, and coupon usage.

### 2.1 System Architecture

The system architecture has of the server, vendor, and consumer component. The consumer can receive advertisements from the server. The vendor can use advertisement editor and upload edited advertisements to the server database. The server can store edited advertisements and publish them on server. The server will publish advertisements to the consumer mobile application.

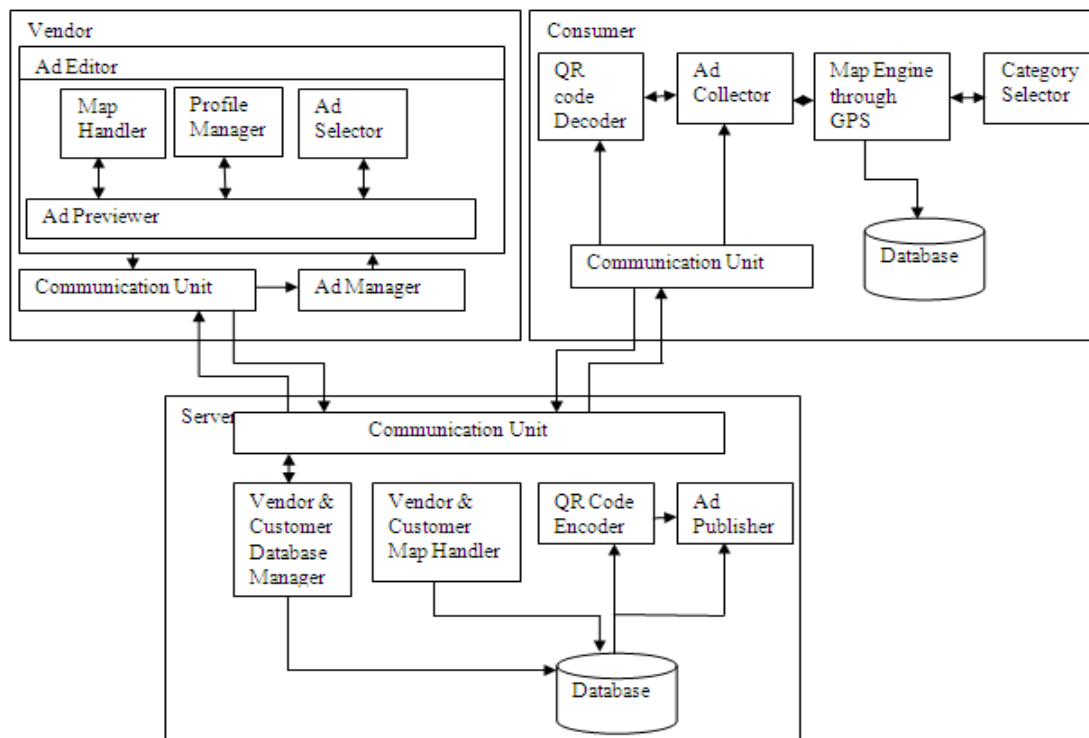

**Fig: System Architecture**

As shown in Fig. 1, the server consists of Communication Unit, AD Manager, Vendor & Customer Database Manager, Vendor & Customer Map Handler, QR code encoder and Ad Publisher. The Communication Unit is used for data communication among vendors, servers and consumers. The AD Manager could store the advertisement information selected or chosen by a consumer or vendor. The Encoder is responsible for encoding the advertisement information created by the vendor. The Publisher is used to publish advertisements to consumer application. In the consumer part, the QR Decoder is to decode scanned QR

code which contained text information of advertisement. The AD Collector stores the advertisement information received by the consumer. The Map Engine through GPS transfers the vendor location information into map form and displays it. Category selector has the category selected by the consumer on application. Finally, the Communication Unit is in charge of transferring between the server and the consumer. The server publishes advertisements through the Communication Unit when new advertisement updated by the vendor.

In the vender part, the AD Editor contains Map Handler, AD Selector, Profile Manager and AD Previewer. The AD Editor provides the vendor an interface to edit the advertisement that will be published. An advertisement contains text information. The vendor could preview an advertisement after editing it through the AD Previewer. The Communication Unit is in charge of the server and the vendor's data communication. The vendor transfers data to the server when the vendor finishes editing an advertisement. The Map Handler is used to add the vendor's location information into an advertisement. The AD Selector allows the vendor to choose the advertisement to upload. The AD Manager has responsibility of storage of advertisement information and updating information on the server.

## **2.2 IMPLEMENTATION**

The advertisement editor is a web application and is implemented by use of various tools, including PHP. In this section, the advertisement editor and advertisement manager will be introduced.

## **3. SYSTEM PROTOTYPE**

In this section the system prototype is described, we divide prototype into three modules as Vendor, Customer and Server.

### **3.1 VENDOR MODULE**

The Vendor module contains advertisement editor which is responsible for collecting text information. The advertisement editor includes text editing, image editing and location information editing.

The vendor can fill in the store name, store category, and coupon description. There is publishing date as well. After editing by the vendor, the advertisement is published to the server. The vendor could edit advertisement or coupon in the text form, and upload pictures to show appealing looks of the goods. With the vendor's address in text, the system can actually show the vendor's location on a map. After searching, the user could press next to view advertisements. The consumer could execute editing advertisement, deleting advertisement, QR and previewing advertisement in the advertisement search form. There is the advertisement editor selection as well. There are store name, description and address on screen. The consumer could also click the advertisement to get more information. Then the consumer can see details of this advertisement, including the vendor's name, promotion product, location, and so on. The consumer only needs to show vendors the coupon to obtain a discount.

### **3.2 CUSTOMER MODULE**

The Customer module contains mechanism that consumer can select the choice category of shop he wants to do the shopping.

The consumer will open the mobile application and select the shop category of his choice. Then application will get the location of the consumer and send it to the server. Then server will search for the advertisement of particular shop category which is selected through the customer with his location information. Mobile application will show the advertisement's short information on map, customer will select one of the advertisements and then detail description about that advertisement displayed on screen. If customer is interested in that advertisement then he will download the QR code in his mobile SD card. When reaching at the Shop then he will show the scanned QR code data to that shop vendor and get the discount.

### 3.3 HARDWARE AND SOFTWARE REQUIREMENTS

#### Hardware Requirements

1. 2 GB RAM
2. 80 GB HardDisk
3. Minimum Dual Core Processor
4. Computer with internet Connection
5. Android Mobile above 4.0 OS with GPS and net connection

#### SOFTWARE REQUIREMENTS

1. Eclipse ADT
2. Eclipse PHP 3.6
3. Android 4.0 and above
4. Web Browser with supporting HTML 5
5. Xampp Server(Apache)
6. MySQL Database Server with minimum version 5.0 or higher

### 4. CONCLUSION

Shopsmart presents a novel location-based mobile advertisement system with vendors ready to use, easiest and convenient way for Digital Advertisement editing and publishing tool. In addition, Customer get ready tool to download the advertisement coupon in QR code format at any location he is. And can take discount from the Vendor by showing scanned QR code. After interviewing with the vendors, most vendors have positive responses and they would consider the adaption of mobile advertisement if the cost is lower than that of their current advertising methods.

### 5. FUTURE SCOPE

1. Notification will be come for new offer in mobile.
2. Increase Distance from Customer to shop on map.
3. Increase category of shops.
4. Online shopping can be done using application.
5. Attractive Advertisements with use of Image, Flash, music in QR code.

### REFERENCES

1. Chyi-Ren Dow, "A Location-based Mobile Advertisement Publishing System for Vendors", 2011 Eighth International Conference on Information Technology: New Generations, pages: 24-29, 2011.
2. Dingqi Yang ; Daqing Zhang ; Zheng, V.W. ; Zhiyong Yu, "Modeling User Activity Preference by Leveraging User Spatial Temporal Characteristics in LBSNs", IEEE Transactions on SYSTEMS, MAN, AND CYBERNETICS: SYSTEMS, Page(s): 129-142, Volume: 45, Issue: 1, 2015.
3. Gedik, B. ; Ling Liu , "Protecting Location Privacy with Personalized k-Anonymity: Architecture and Algorithms", IEEE Transactions on Mobile Computing, Page(s): 1-18, Volume: 7, Issue: 1, 2008.
4. Dong Li ; Sinha, P., "RBTP: Low-Power Mobile Discovery Protocol through Recursive Binary Time Partitioning"IEEE Transactions on Mobile Computing, Page(s): 263- 273, Volume: 13, Issue: 2, 2014.
5. Dutta, A. ; Schulzrinne, Henning, "MarconiNet: overlay mobile content distribution network", IEEE Communications Magazine, Page(s): 64- 75, Volume: 42, Issue: 2, 2004.
6. developer.map.google.com
7. developer.android.com